

*** PLEASE NOTE:** Before beginning installation, check that parts contained in the carton and hardware package match those parts listed below. If you should find any discrepancies please contact Holcam Sales at 1-800-843-3332

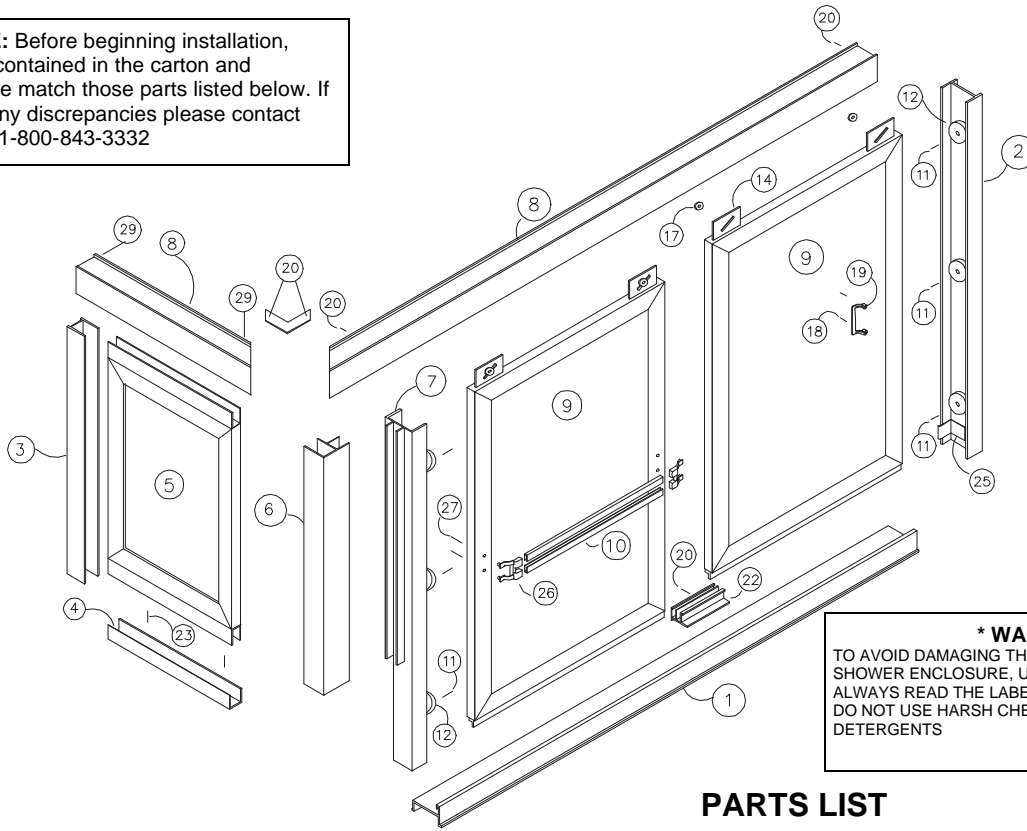

*** WARNING***
TO AVOID DAMAGING THE FINISH OF THIS DELUXE SHOWER ENCLOSURE, USE ONLY MILD CLEANERS. ALWAYS READ THE LABEL ON THE CLEANER USED. DO NOT USE HARSH CHEMICALS OR ABRASIVE DETERGENTS

PARTS LIST

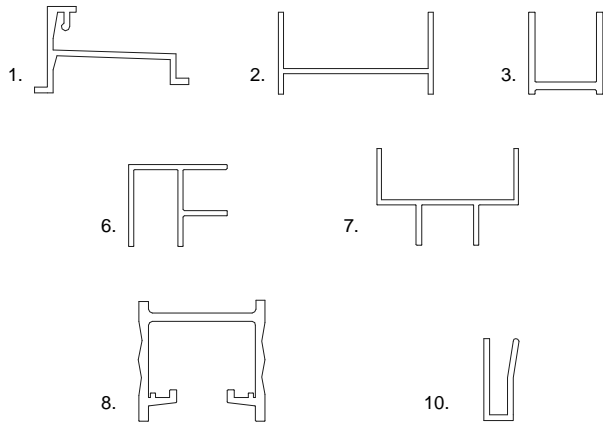

ITEM	NAME	QTY	PART #
1.	Threshold	1	H-200
2.	Wall Jamb	1	H-12
3.	Wall Jamb	1	H-36
4.	Filler	1	H-36
5.	End Panel	1	
6.	Corner Post	1	H-24
7.	Step Jamb	1	H-41
8.	Header	2	H-15
9.	Glass Panels	2	
10.	Towel Bars	2	H-75

HARDWARE PACK

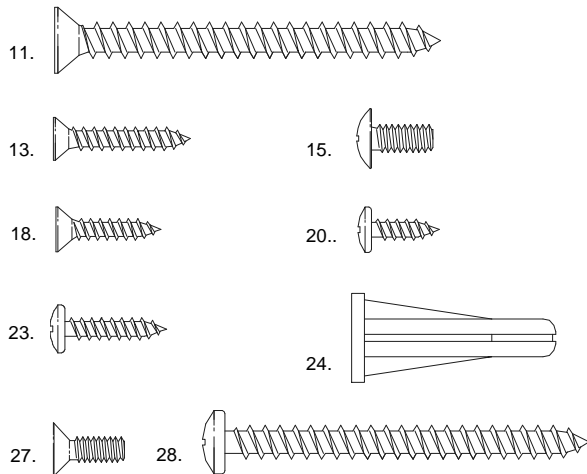

11.	10 X 2" Flat Head Screw	4
12.	Bumpers	6
13.	10 x 3/4" Flat Head Screw	3
14.	Hanger Bracket	4
15.	8-32 x 3/8" Truss Head Screw	4
16.	Lock Washers	4
17.	Rollers	4
18.	8 x 5/8" Flat Head Screw	2
19.	Handle	1
20.	6 x 3/8" Pan Head Screw	30
21.	Splice Plate	1
22.	Panel Guide	1
23.	8 x 1" Pan Head Screw	2
24.	Plastic Anchors	6
25.	Jamb Guide	2
26.	Towel Bar Brackets	2
27.	8-32 x 7/16" Machine Screw	4
28.	10 x 2" Pan Head Screw	3
29.	6X3/4" Pan Head Screw	2

INSTALLATION INSTRUCTIONS MODEL AT-14 STEP PANEL RETURN

1. Measure centerline of sill. Subtract 1/2" from measurement and cut #1, threshold to length. Place track on sill with slope going towards the inside of shower.

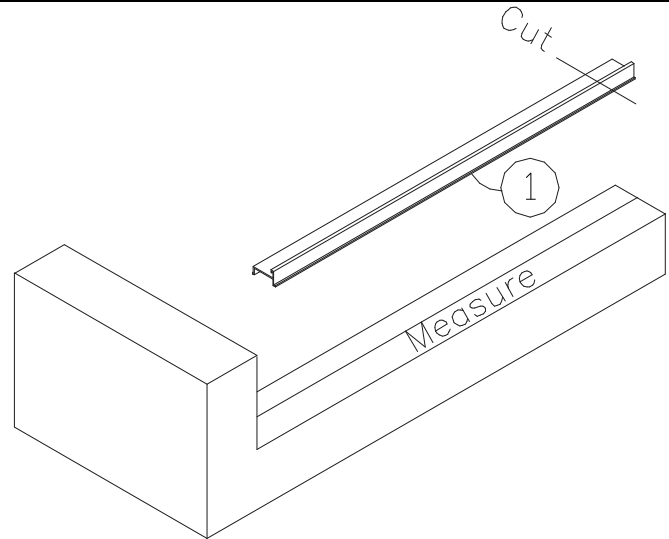

2. Place wall jamb #2 down over end of threshold, plumb, mark hole locations. Drill 1/4" holes, insert plastic anchors and secure to wall with 10x2" flat head screws through bumpers.

NOTE: On some tubs and showers it may be necessary to radius corner of wall jamb and track to match the radius of the sill.

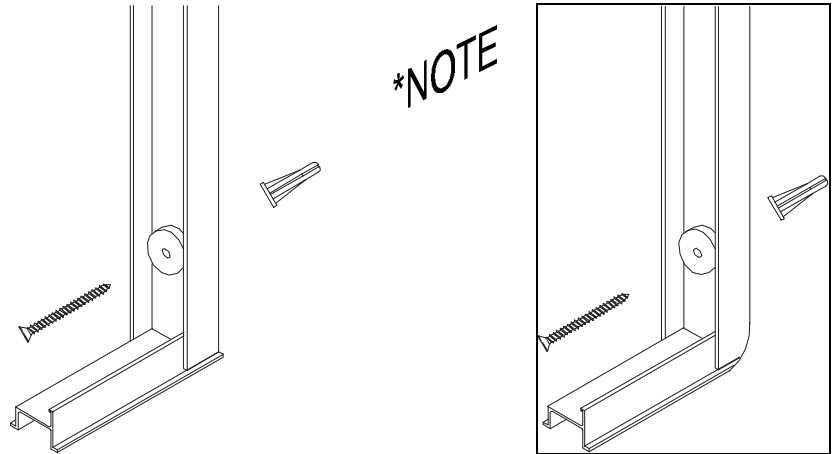

3. Place step jamb #7, down over end of threshold, plumb and mark hole location. Drill 1/4" hole and insert plastic anchor. Secure jamb to stub wall with 10x2" flat head screw through bumper.

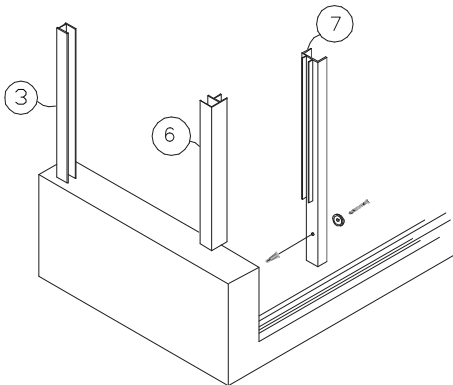

4. Assemble #6 corner post and #7 wall jamb, hold in place at corner of threshold. Position #3 step wall jamb inline with corner post. Plumb and mark hole locations. Drill 1/4" holes and insert plastic anchors. Secure jamb to wall with 10x2" pan head screws.

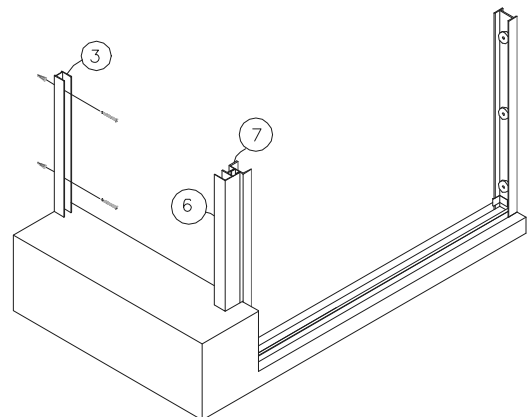

5. Measure in-between step wall jamb and corner post. Cut #4, filler to size. Drill two or more drain holes along inside bottom edge of filler. Filler may be secured with anchors and screws or siliconed in place.

Remove #6, corner post and install #5 panel into wall jamb and filler. Re-install #6 corner post on panel and on #7, step wall jamb. Align panel within jambs. Drill 1/8" holes through jambs and panel rails. Secure with #20 6x3/8" screws.

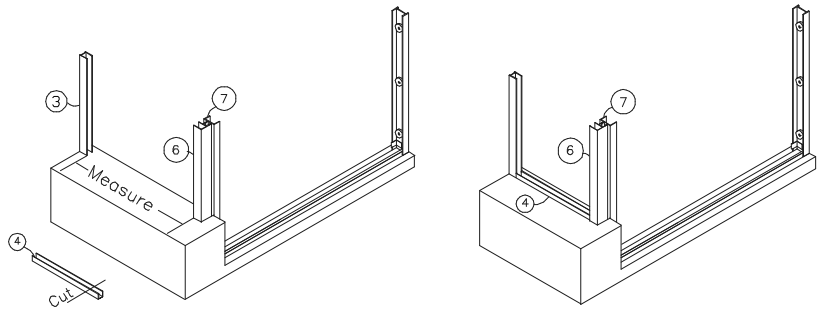

6. Measure from wall to corner of post, add 5/8" to this measurement on the long side of header. Cut header and place header in position on top of wall jamb and corner post. Measure from corner of panel header to wall on door side, cut header to this dimension.

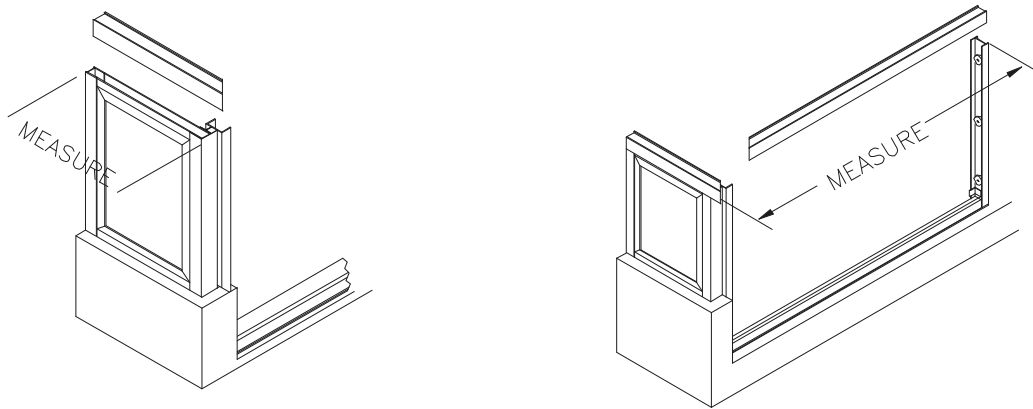

7. Remove headers and assemble with splice plate and 6x3/8" screws. Position headers to match at mitered corner, locate splice plate on top of headers and drill through splice plate and headers. Secure header and splice plate with 6x3/8" screws.

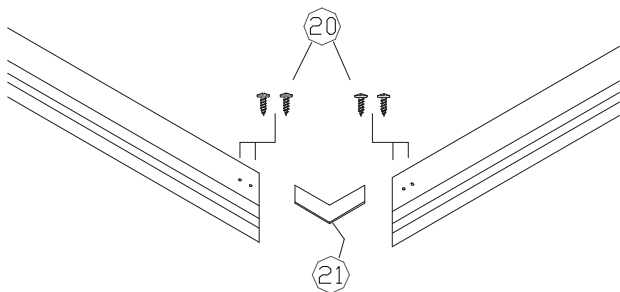

8. Install header assembly, drill 1/8" holes through header and jambs. Secure header to jambs with 8x1" pan head screws and one 6x3/8" screw. Drill and install bumpers on step wall jamb using 10x3/4" flat head screws.

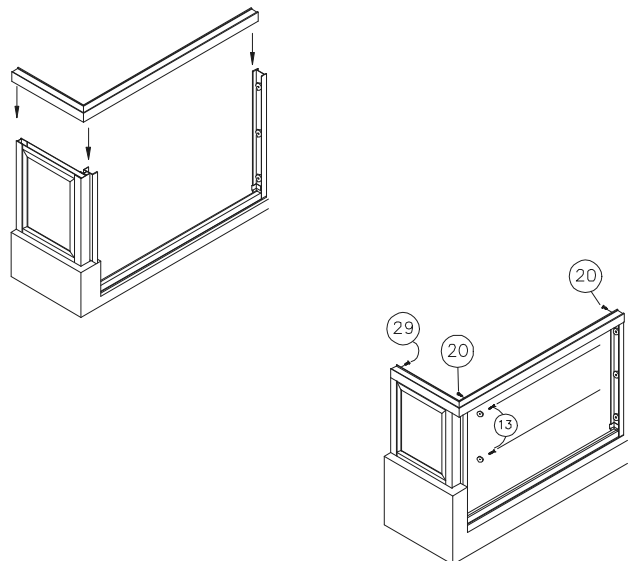

9. Assemble door panels. See end view for location and position of brackets and rollers.

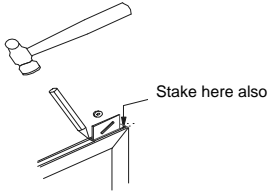

Slide hanger bracket into channel on top of panel. position bracket even with side rail and crimp channel down onto bracket.

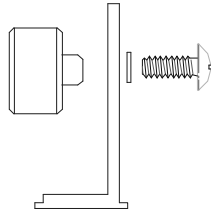

Install rollers on hanger brackets as illustrated. Center roller on bracket and secure with 8-32x3/8" truss head screw and lockwasher.

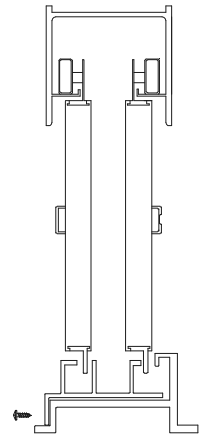

END VIEW

10. Install one # 26 towel bar bracket on outside panel with two 8-32 x 7/16" machine screws. Insert both # 10 towel bars and install the second towel bar bracket

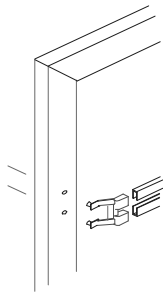

11. Install handle on inside panel with two # 18, 8X5/8" flathead screws. Hang and adjust panels from inside of tub. Hang outside panel, then hang inside panel.

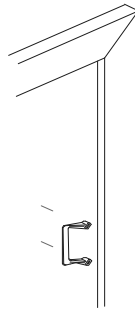

Adjustment to bring door panels flush with wall jambs may be made by moving rollers in the diagonal slot in hanger bracket

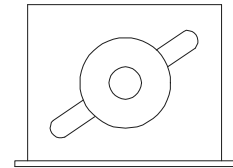

12. Slide # 22 guide to center of track. Drill 1/8" hole through panel guide and track. Secure guide to track with one # 20, 6x3/8" pan head screw.

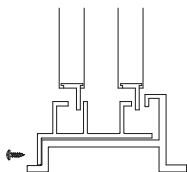

Install # 25 jamb guide by removing tape backing and then attaching at lower inside leg of wall jamb as shown.

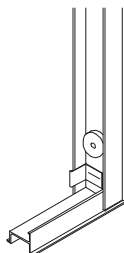

TOP VIEW

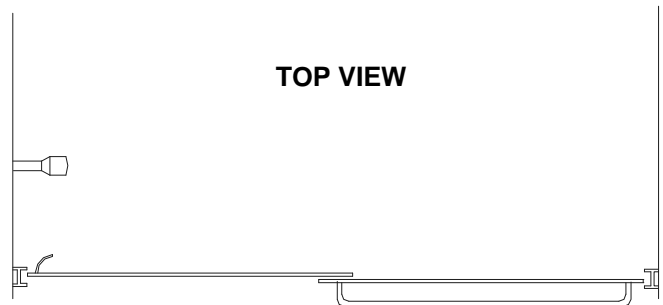

SEALING INSTRUCTIONS

We recommend filling any sharp corners that could cause injury. Clean unit thoroughly and run a continuous bead of silicone on outside leading edge of unit. Also seal where wall jamb and track meet. Do not seal inside edge of unit to allow for drainage. Allow sealant to cure for 24 hours before using shower.