

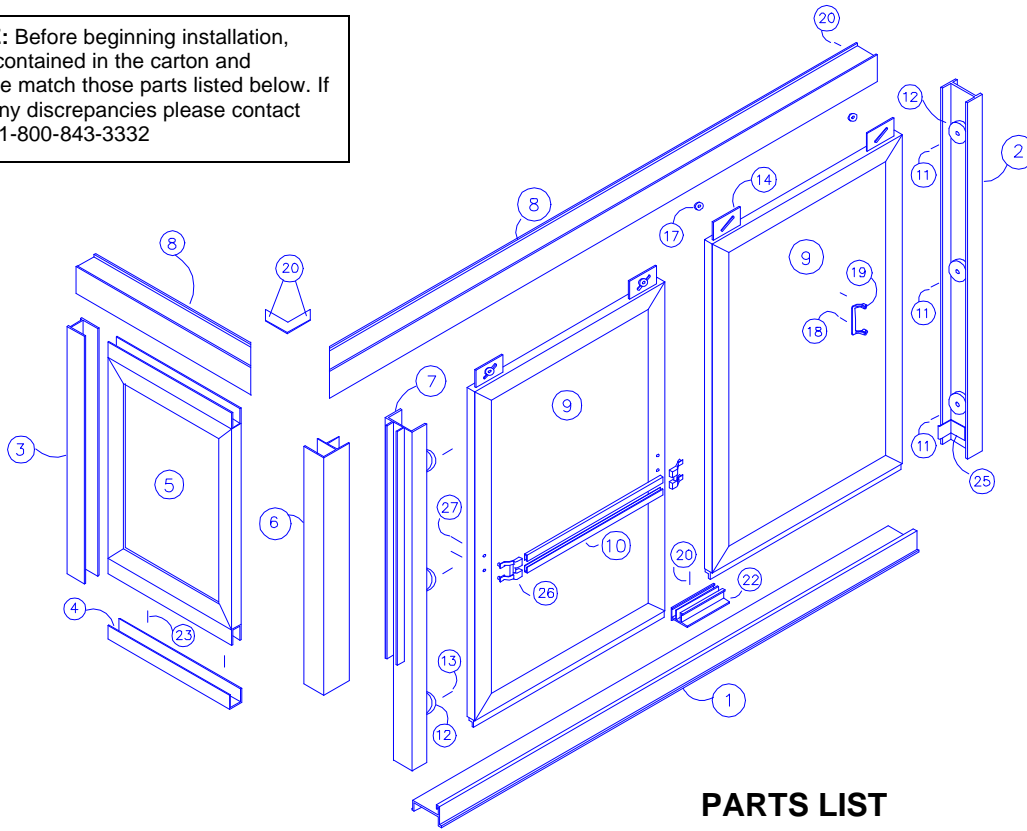

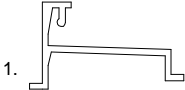







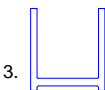
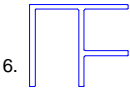
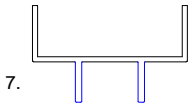
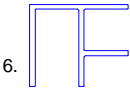
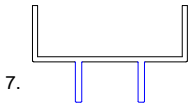
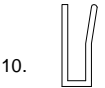
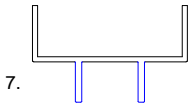
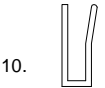

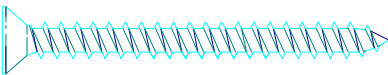
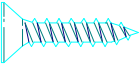
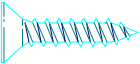
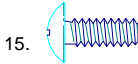
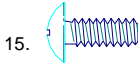
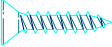
**\* PLEASE NOTE:** Before beginning installation, check that parts contained in the carton and hardware package match those parts listed below. If you should find any discrepancies please contact Holcam Sales at 1-800-843-3332

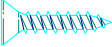

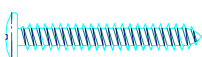
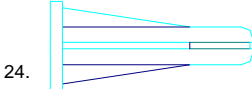
**PARTS LIST**

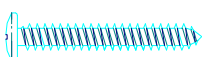
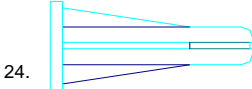
ITEM	NAME	QTY	PART #
	1. Threshold	1	H-200
	2. Wall Jamb	1	H-12
	3. Wall Jamb	1	H-36
	4. Filler	1	H-36
	5. End Panel	1	
	6. Corner Post	1	H-24
	7. Step Jamb	1	H-41
	8. Header	2	H-15
	9. Glass Panels	2	
	10. Towel Bars	2	H-75

**HARDWARE PACK**

	11. 10 X 2" Flat Head Screw	3
	12. Bumpers	6
	13. 8 x 3/4" Head Screw	3
	14. Hanger Bracket	4
	15. 8-32 x 3/8" Machine Screw	4
	16. Lock Washers	4
	17. Rollers	4
	18. 6 x 5/8" Flat Head Screw	2
	19. Handle	1
	20. 6 x 3/8" Pan Head Screw	21
	21. Splice Plates	1
	22. Panel Guide	1
	23. 8 x 1" Pan Head Screw	6
	24. Plastic Anchors	6
	25. Jamb Guide	2
	26. Towel Bar Brackets	2
	27. 8-32 x 7/16" Machine Screw	4

# INSTALLATION INSTRUCTIONS MODEL F-14 STEP PANEL RETURN

1. Measure centerline of sill. Subtract 1/2" from measurement and cut #1, threshold to length. Place track on sill with slope going towards the inside of shower.

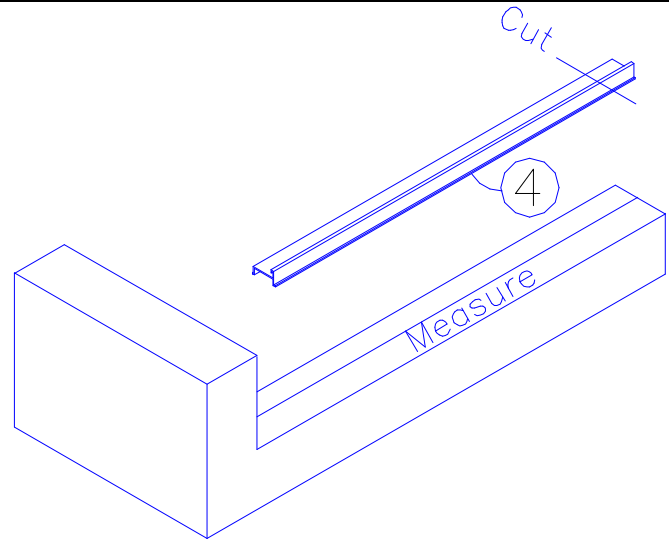

2. Place wall jamb #2 down over end of threshold. Plumb, mark hole locations. Drill 1/4" holes, insert plastic anchors and secure to wall with 10x2" flat head screws through bumpers.

**NOTE:** On some tubs and showers it may be necessary to radius corner of wall jamb and track to match the radius of the sill.

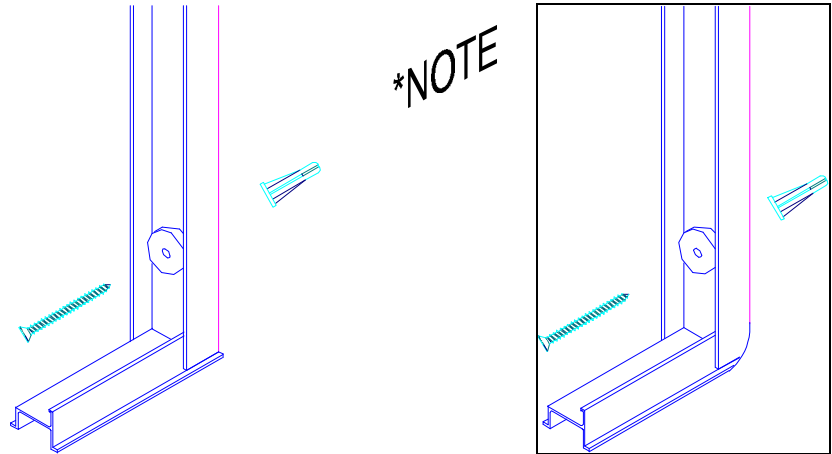

3. Place step corner #6 down over end of threshold. Plumb and mark hole location. Drill 1/4" hole and insert plastic anchor. Secure jamb to stub wall with 10x2" flat head screw through bumper.

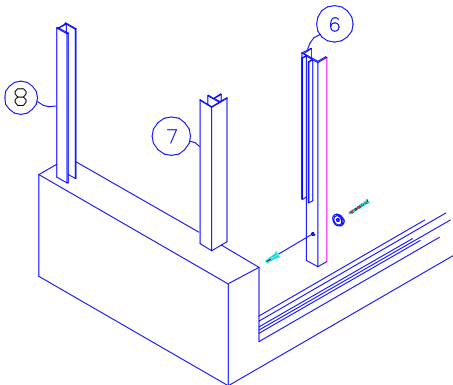

4. Assemble #7 corner post and #6 corner wall jamb, hold in place at corner of threshold. Position #3 step wall jamb in line with corner post. Plumb and mark hole locations. Drill 1/4" holes and insert plastic anchors. Secure jamb to wall with 10x2" pan head screws.

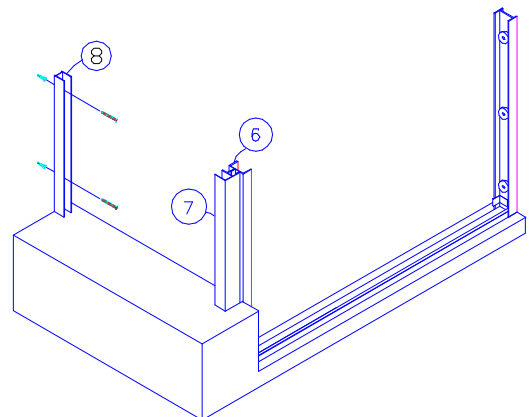

5. Measure in-between step wall jamb and corner post. Cut #4, filler to size. **Drill two or more drain holes along inside bottom edge of filler.** Filler may be secured with anchors and screws or siliconed in place.

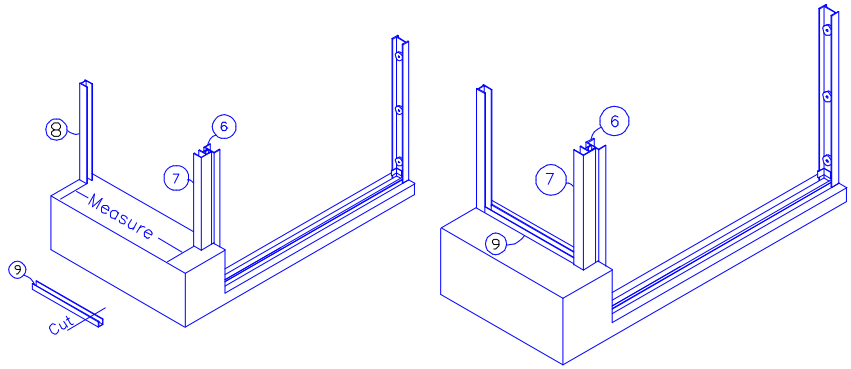

6. Measure from wall to corner of post, add 1" to this measurement on the long side of header. Cut header and place header in position on top of wall jamb and corner post. Measure from corner of panel header to wall on door side, cut header to this dimension.

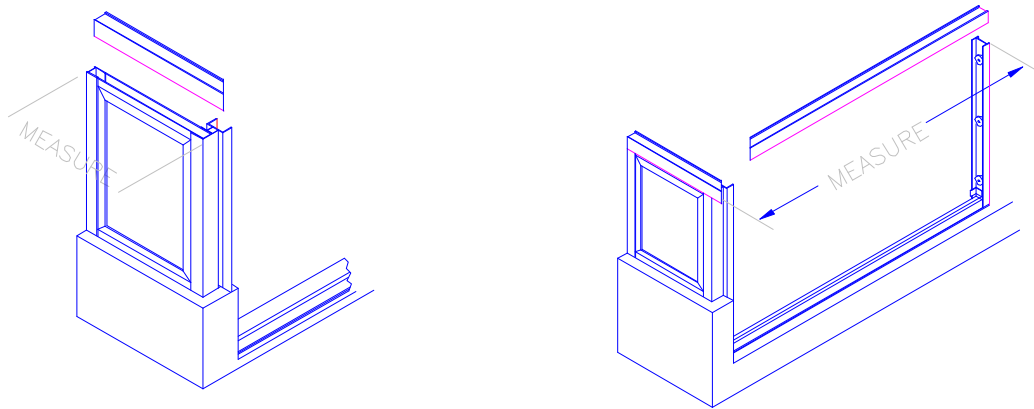

7. Remove headers and assemble with splice plate and 6x3/8" screws. Position headers to match at mitered corner, locate splice plate on top and drill through splice plate and header. Secure header and splice with 6x3/8" screws.

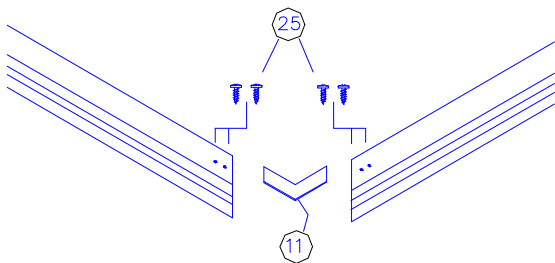

8. Install header assembly, drill 1/8" holes through header and jambs. Secure header to step wall jamb with #6x3/4" pan head screw at location #26. Secure header to with #6x3/8" pan head screws at location #25. Drill and install bumpers on step wall jamb using #10x3/4" flat head screws.

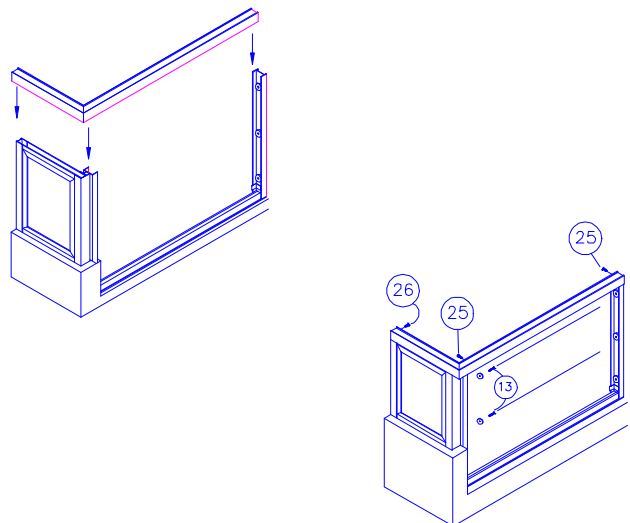

9. Assemble door panels. See end view for location and position of brackets and rollers.

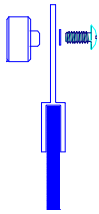

Install rollers on hanger brackets as illustrated. Center roller on bracket and secure with 8-32x3/8" truss head screw and lockwasher.

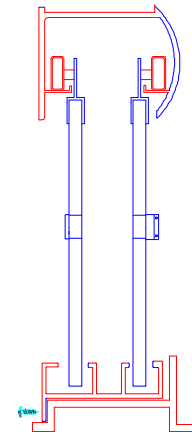

END VIEW

Determine placement of finger pulls and towel bars by measuring up from bottom edge of glass panel. Place rubber pad around edge of glass. Tap finger pulls and towel bar brackets into place over rubber pad. Trim excess rubber even with edge of bracket. Install towel bars with 6x3/4" pan head screws through brackets.

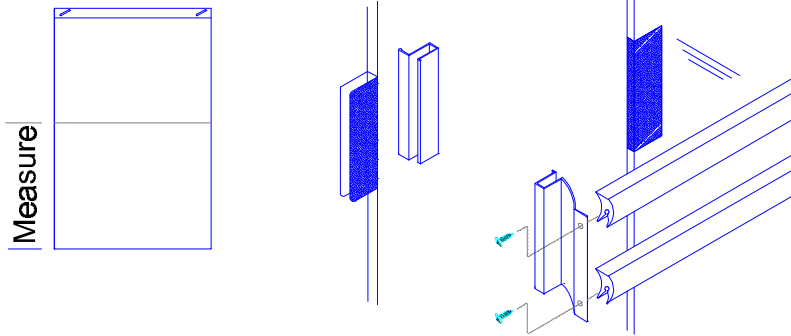

Adjustment to bring door panels flush with wall jambs may be made by moving rollers in the diagonal slot in hanger bracket

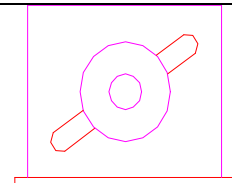

To hang and adjust panels, begin from the inside of tub. Hang and adjust outside panel, then hang and adjust inside panel

12. Slide #24 guide to center of track under panels. Drill 1/8" hole through guide and track. Secure guide to track with one # 25, 6x3/8" pan head screw.

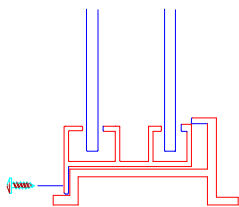

Install #16 jamb guide by removing tape backing and then attaching at lower inside leg of wall jamb as shown.

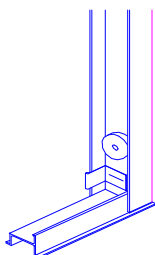

TOP VIEW

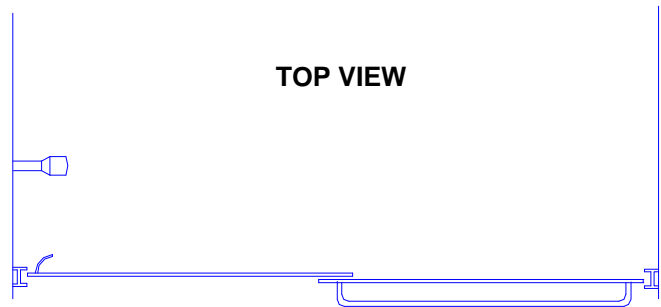

### SEALING INSTRUCTIONS

We recommend filling any sharp corners that could cause injury. Clean unit thoroughly and run a continuous bead of silicone on outside leading edge of unit. Also seal where wall jamb and track meet. Do not seal inside edge of unit to allow for drainage. Allow sealant to cure for 24 hours before using shower.