

**\* PLEASE NOTE:** Before beginning installation, check that parts contained in the carton and hardware package match those parts listed below. If you should find any discrepancies please contact Holcam Sales.

1-800-843-3332  
www.Holcam.com  
Holcam@worldnet.att.net

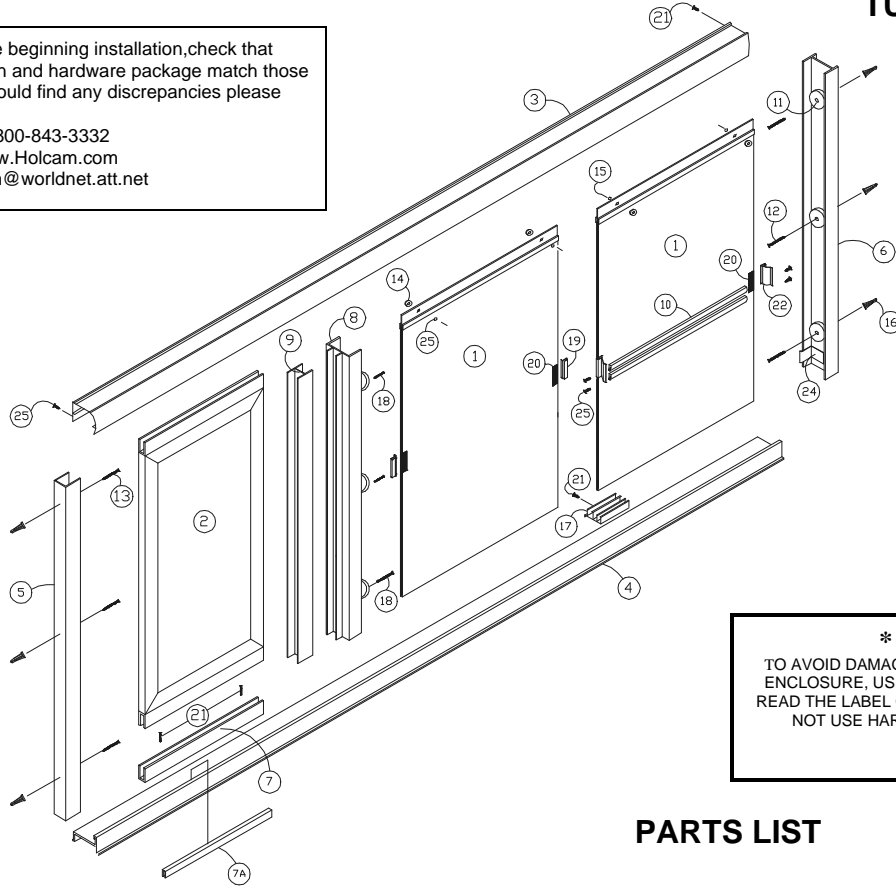

**\* WARNING\***  
TO AVOID DAMAGING THE FINISH OF THIS DELUXE ENCLOSURE, USE ONLY MILD CLEANERS. ALWAYS READ THE LABEL ON THE CLEANER TO BE USED. DO NOT USE HARSH CHEMICALS OR ABRASIVE DETERGENTS

**PARTS LIST**

ITEM	NAME	QTY	PART #
1.	Glass Door Panel	2	
2.	End Panel	1	
3.	Header	1	H-215
4.	Threshold	1	H-200
5.	Panel Wall Jamb	1	H-36
6.	Wall Jamb	1	H-12
7.	Bottom Channel	1	H-36
7A.	Filler	1	H-58
8.	Transition Door Jamb	1	H-41
9.	Transition Filler	1	H-35
10.	Towel bar	2	H-125

**HARDWARE PACK**

11.	Bumper	6
12.	10 x 2" Flat Head Screw	3
13.	10 x 2" Pan Head screw	3
14.	Rollers	4
15.	8-32 x 3/8" Truss Head Screw	4
16.	Plastic Anchor	6
17.	Panel Guide	1
18.	10 x 3/4" Flat Head Screw	3
19.	Finger Pull	2
20.	Rubber Pad	4
21.	6 x 3/8" Pan Head Screw	16
22.	Towel Bar Brackets	2
23.	#8 Lock Washer	4
24.	Jamb Guide	2
25.	6 x 3/4" Pan Head Screw	6

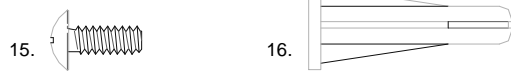
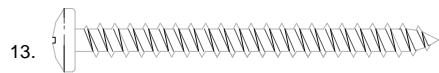
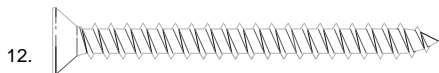
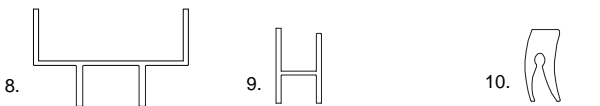
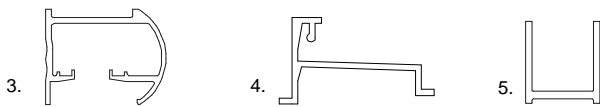

# INSTALLATION INSTRUCTIONS MODEL F-14 INLINE TUB ENCLOSURE

1. Measure centerline of sill. Cut #4 threshold 3/8" less than measurement. Position threshold with slope towards the inside of the stall. Note: It may be necessary to radius threshold and wall jamb to match radius of stall.

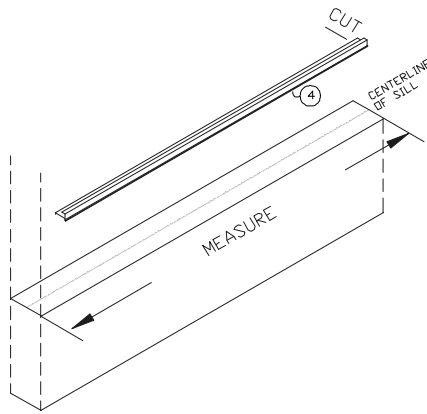

**\*NOTE**

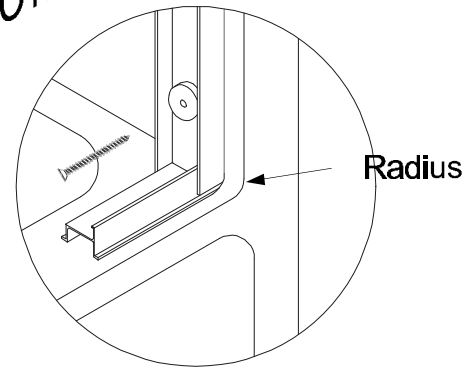

2. Place wall jamb #6 down over end of threshold, plumb and mark hole locations. Drill 1/4" holes. Insert plastic anchors and secure jamb to wall with #10 x 2" flat head screws through bumpers.

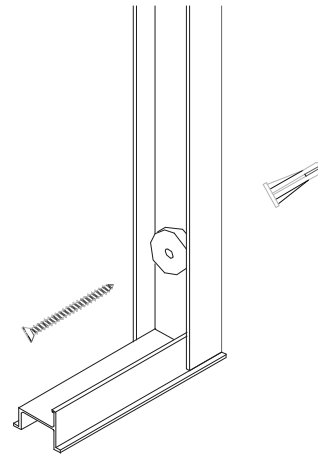

3. Center #5, panel wall jamb on track. Plumb jamb and mark hole locations. Drill 1/4" holes. Insert plastic anchors and secure jamb to wall with #10x2" pan head screws. Slide panel into wall jamb.

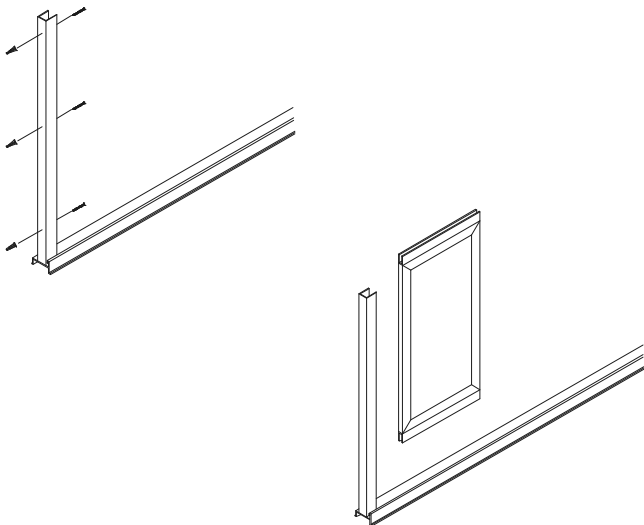

4. Install transition filler and transition door jamb on panel. Plumb panel and jambs. Measure distance in between wall jamb and panel jamb. Cut bottom filler to size.

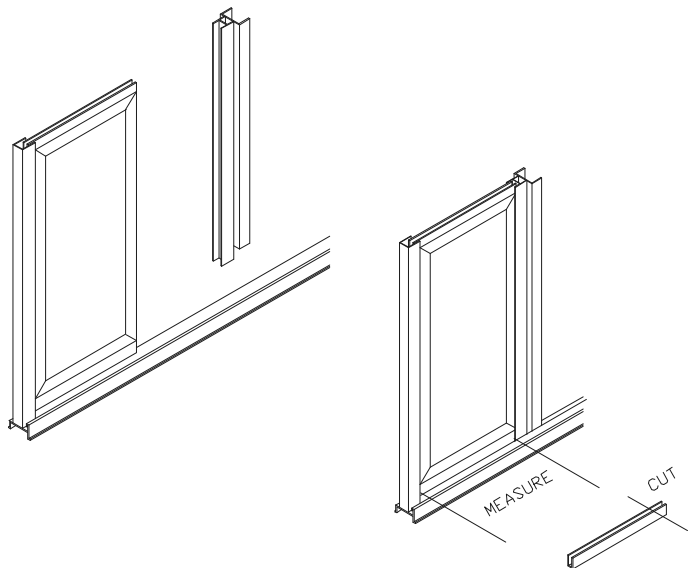

---

5. Measure from the back edge of #8, transition jamb to the wall. Cut filler #7A to size. Filler #7A is used to fill area between panel and the front lip of threshold. Install filler inside lip of the threshold. Remove transition jambs and panel. Install bottom channel on threshold by drilling 1/8" holes through channel and threshold. Secure channel to threshold with #6x3/8" pan head screws.

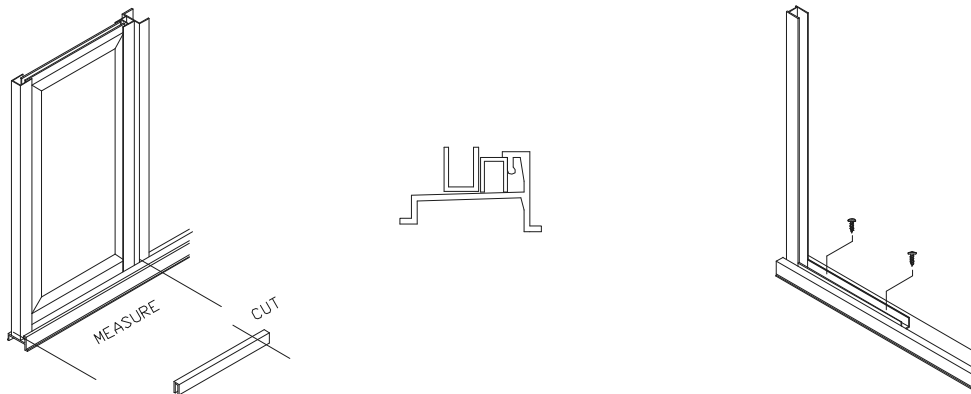

---

6. Reinstall panel in bottom channel and wall jamb. Plumb panel. Drill evenly spaced 1/8" holes through wall jamb and panel rail. Secure panel to wall jamb with #6x3/8" panhead screws. Repeat on opposite side of wall jamb. Install transition filler on panel. Drill 1/8" holes through transition filler and panel rail. Secure filler to panel with #6x3/8" pan head screws. Install transition door jamb and secure with #6x3/8" pan head screws.

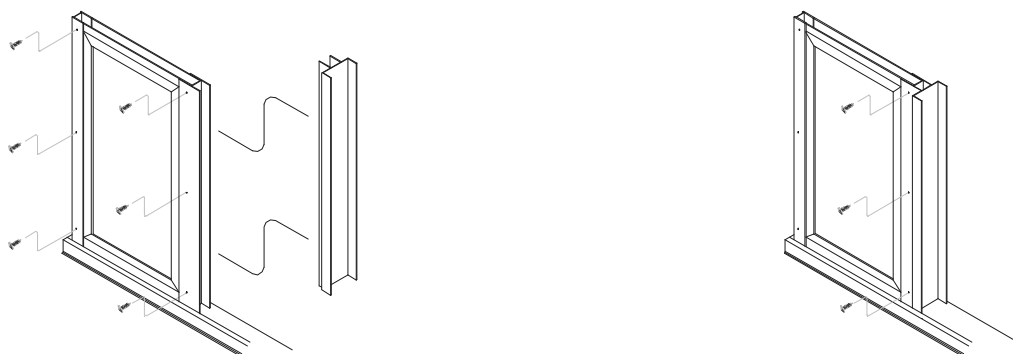

---

7. Measure wall to wall at top of unit. Cut the header 1/16" less than measurement. Install header over the top of wall jambs. Secure header to jambs at location A & B with # 6x3/8" pan head screws. Secure header at location C with # 6x3/4" pan head screw.

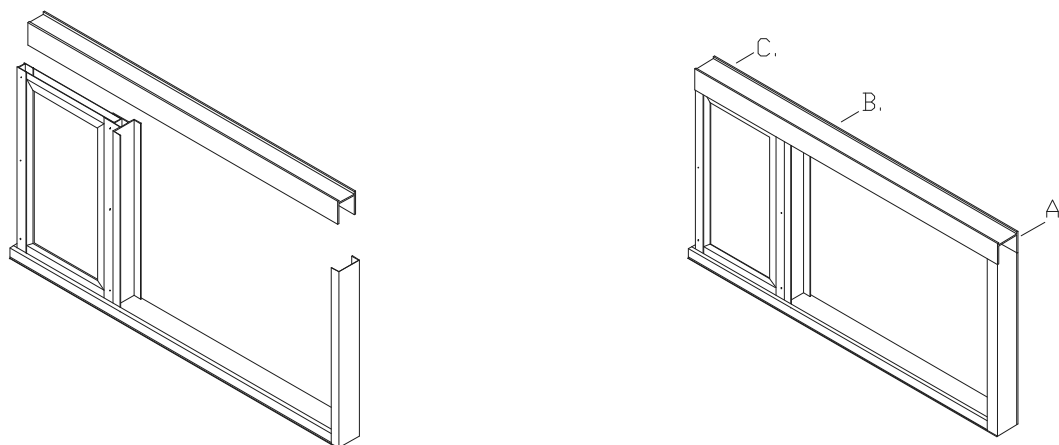

9. Assemble door panels. See end view for location and position of brackets and rollers.

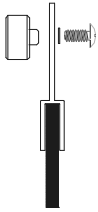

Install rollers on hanger brackets as illustrated. Center roller on bracket and secure with 8-32x3/8" truss head screw and lockwasher.

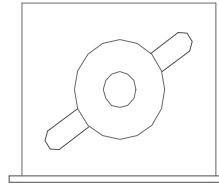

Adjustment to bring door panels flush with wall jambs may be made by moving rollers in the diagonal slot in hanger bracket.

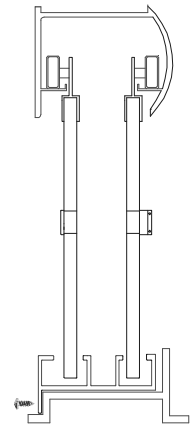

END VIEW

10. Install # 24, towel bar brackets on outside panel. Determine placement of towel bar brackets by measuring up from bottom edge of glass panel. Place rubber pad around edge of glass and tap bracket into place. Trim excess rubber even with edge of bracket. Install towel in brackets with #25, 6x3/4" pan head screws.

11. Install finger pulls on inside panel. Determine placement of finger pulls by measuring up from bottom edge of glass panel. Place rubber pad around edge of glass and tap finger pull into place. Trim excess rubber even with finger pull. Hang and adjust panels to wall jambs. From inside of tub hang and adjust outside panel, then hang and adjust inside panel.

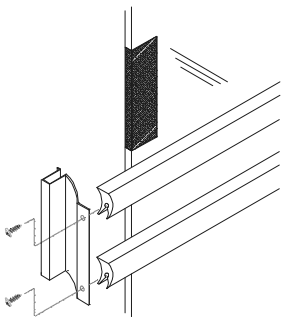

Measure

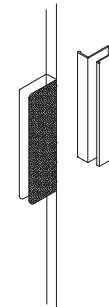
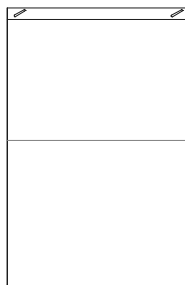

12. Place # 21 guide at center of track, mark hole location and drill 1/8" hole in track. Secure guide to track with one 6x3/8" pan head screw.

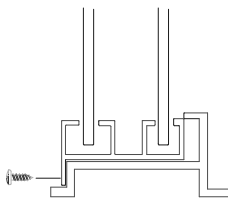

Install # 23 jamb guide by removing tape backing and then attaching at lower inside leg of wall jamb as shown.

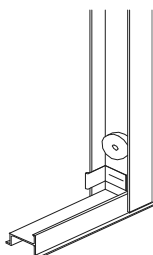

TOP VIEW

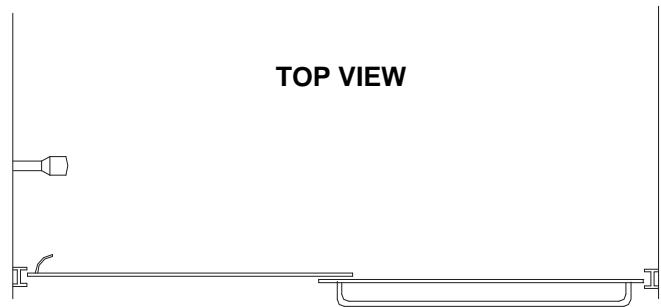

### SEALING INSTRUCTIONS

We recommend filling any sharp corners that could cause injury. Clean unit thoroughly and run a continuous bead of silicone on outside leading edge of unit. Also seal where wall jamb and track meet. Do not seal inside edge of unit to allow for drainage. Allow sealant to cure for 24 hours before using shower.